

MODEL YV-950

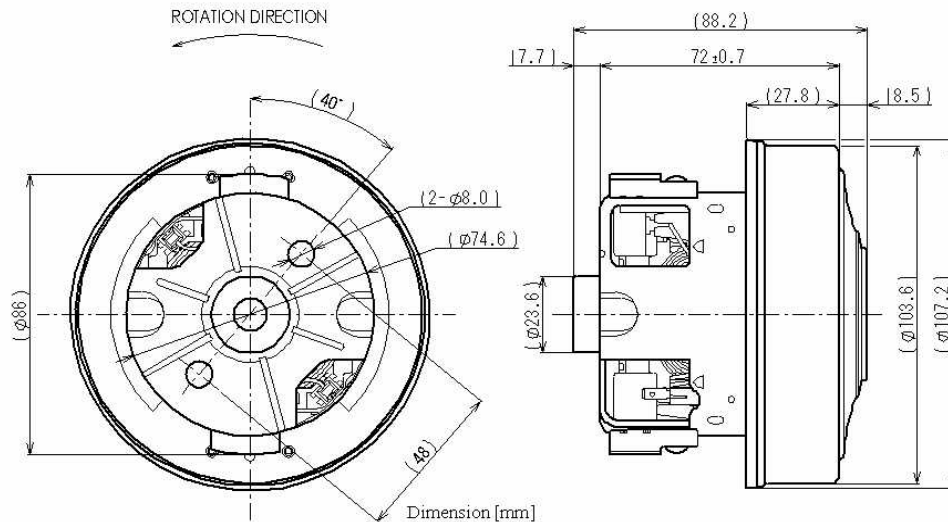

Voltage (電圧)	100v (50/60Hz)
Input Power Max. (入力)	530W at open
Output Max. (出力)	190W at 15dm ³ /s
Vacuum Max. (真空圧)	19.3kPa
Airflow Max. (風量)	30.5dm ³ /s at open
Efficiency Max. (効率)	40% at 15dm ³ /s
Rotational Frequency Min. (回転数)	3130r/min
Life (寿命)	200h
Mass (重量)	0.59kg
Insulation Class (絶縁クラス)	E
Remarks (備考)	100v Only

